

Sound **Acoustics**

SA-44

**8 Channel
Controller-Amplifier**

Installation Instructions

Important Safety Instructions

- 1) Read these instructions.
- 2) Keep these instructions.
- 3) Read all warnings.
- 4) Follow all instructions.
- 5) Do not use this apparatus near water.
- 6) Clean only with dry cloth.
- 7) Do not block any ventilation openings. Install in accordance with the manufacturer's instructions.
- 8) Do not install near any heat sources such as radiators, heat registers, stoves, or other apparatus (including amplifiers) that produce heat.
- 9) Do not defeat the safety purpose of the polarized or grounding-type plug. A polarized plug has two blades with one wider than the other. A grounding type plug has two blades and a third grounding prong. The wide blade or the third prongs are provided for your safety. If the provided plug does not fit into your outlet, consult an electrician for replacement of the obsolete outlet.
- 10) Protect the power cord from being walked on or pinched particularly at plugs, convenience receptacles, and the point where they exit from the apparatus.
- 11) Only use attachments/accessories specified by the manufacturer.
- 12) Use only with the cart, stand, tripod, bracket, or table specified by the manufacturer, or sold with the apparatus. When a cart is used, use caution when moving the cart/apparatus combination to avoid injury from tip-over.
- 13) Unplug this apparatus during lightning storms or when unused for long periods of time.
- 14) Refer all servicing to qualified service personnel. Servicing is required when the apparatus has been damaged in any way, such as power-supply cord or plug is damaged, liquid has been spilled or objects have fallen into the apparatus, the apparatus has been exposed to rain or moisture, does not operate normally, or has been dropped.
- 15) Under no circumstances should the output terminals of the amplifier be short-circuited.
- 16) Be sure that the loudspeakers connected can handle the output power of the amplifier at the loudspeakers rated impedance. The warranty on the amplifier does not cover damage to loudspeakers that have inadequate power handling capabilities.
- 17) Where an all-pole MAINS SWITCH is used as the disconnect device, the location on the apparatus and the function of the switch shall be described, and the switch shall remain readily operable.
- 18) A push button is used to turn the power off and on.
- 19) When the front panel push button switch is in the in position the apparatus is powered on.

CAUTION: These servicing instructions are for use by qualified service personnel only. To reduce the risk of electric shock, do not perform any servicing other than that contained in the operating instructions unless you are qualified to do so.

Note: Where the mains plug or an appliance cover is used as the disconnect device, the disconnect device shall remain readily operable.

WARNING: This product may contain chemicals, including lead, known to the State of California to cause birth defects or other reproductive harm. Wash hands after handling.

FCC Warning

Note: This equipment has been tested and found to comply with the limits for a Class B digital device, pursuant to part 15 of the FCC Rules. These limits are designed to provide reasonable protection against harmful interference in a residential installation. This equipment generates, uses and can radiate radio frequency energy and, if not installed and used in accordance with the instructions, may cause harmful interference to radio communications. However, there is no guarantee that interference will not occur in a particular installation. If this equipment does cause harmful interference to radio or television reception, which can be determined by turning the equipment off and on, the user is encouraged to try to correct the interference by one or more of

the following measures:

- Reorient or relocate the receiving antenna.
- Increase the separation between the equipment and receiver.
- Connect the equipment into an outlet on a circuit different from that to which the receiver is connected.
- Consult the dealer or an experienced radio/TV technician for help.

Canada

This Class B digital apparatus complies with Canadian ICES-003.

Cet appareil numérique de la classe B est conforme à la norme NMB-003 du Canada.

Caution: To reduce the risk of electrical shock, do not remove the cover (or back). No user serviceable parts inside. Refer to qualified service personnel.

Warning: To reduce the risk of fire or electric shock, do not expose this appliance to rain or moisture.



The lightning flash with arrowhead, within an equilateral triangle, is intended to alert the user to the presence of uninsulated "dangerous voltage" within the products that may be of sufficient magnitude to constitute a risk of electrical shock to persons.



The exclamation point within an equilateral triangle is intended to alert the user to the presence of important operation maintenance (servicing) instructions in the literature accompanying the appliance.

Note: It is very important to use a top quality RJ45 8/8 crimper tool. We strongly suggest using a cat 5 / RJ45 electronic tester to verify the wire conductors.

Introduction

Thank you for your purchase of a Sound Acoustics SA-44 8 channel controller amplifier and congratulations on your choice. The SA-44 features four deluxe digital volume controlled stereo amplifiers with individual four source selection. The SA-44 is designed to meet the amplifier needs of custom installed multi-zone systems where high quality sound is a specific requirement. Each of the four zones or rooms can select any of the four inputs, with individual volume control, bass and treble. Extras such as an external voltage trigger that can turn source equipment on and off, individual zone infrared outputs and many more features give the SA-44 exceptional value when installed in homes and large complex systems. Except for the power button all controls are rear mounted. A data port is provided for ganging multiple SA-44's. Infrared signals can be relayed from the keypads to the source equipment.

The SA-44 is controlled by SA-40 keypads.

- Four input source selection. Each of the four stereo amplifiers is provided with four input source selection. Selection, volume level, bass and treble is made on SA-40 keypads or a Sound Acoustics remote control (or a programmed remote control). Rooms can have different source selections, volumes, etc.
- Four internal 80 position stereo volume controls. The four zones each require a SA-40 keypad. The Sound Acoustics SA-40R remote control (or a programmed remote control) in conjunction with the SA-40 keypad can control each zone. The keypads are typically mounted in the room with the speakers and they control amplifier power on/off, volume up/down and mute as well as source selection.
- Cost and size efficiency. The SA-44 consists of a total of 8 power amplifiers in one 3-1/2" high enclosure (two rack spaces). Each power amplifier channel can deliver 30 watts RMS with peaks of 60 watts. Because of its unique design the SA-44 delivers exceptional value.
- Automatic protection circuitry. Each SA-44 amplifier channel is individually and fully protected against low impedance, overheating, overloading, over voltage and under voltage. The protection circuitry automatically restores the amplifier channel as soon as its parameter returns to the safe operating area.
- Individual bass and treble adjustment. Each channel features adjustments so installers can preset the room for speaker differences and listener preferences.
- External trigger. The SA-44 can turn on and off source components with its 12vdc trigger output.
- Infrared controller ports. Each zone or room has its own infrared output jack. An all zone jack is also provided.
- Zone 1 has line level outputs so more powerful power amplifiers can be connected to this output. The line level output is controlled as to volume, bass, treble and source selection.

Unpacking

The carton and packing materials used in shipping your new amplifier were specially designed to protect it from the shock and vibration of shipping. We suggest that you save the carton and packing materials to use if you move, or if the unit ever needs to be shipped back to us for any reason. Should you discover that your amplifier has been damaged during shipping, please contact your dealer or Sound Acoustics immediately and request the name of the carrier so a written claim can be made.

The right to a claim against a public carrier can be forfeited if the carrier is not notified immediately in writing and if the shipping carton and packing materials are not available for inspection by the carrier. Save all packing materials until the claim is settled.

Amplifier Placement

During normal home operation the amplifier will become warm. However, there are instances during high-level playback into low impedance speakers when the amplifier will become much warmer than normal. To ensure the amplifier's trouble-free operation, it is necessary to provide adequate ventilation. Your amplifier should be kept away from external sources of heat such as radiators and hot-air ducts. The amplifier should never be placed with other heat-producing components in a cabinet or enclosure lacking free airflow. Do not stack other components on top of your amplifier.

Connecting Your Amplifier

When making connections between any source components and the amplifier, or when making connections to any speaker, be certain that both the input devices and the amplifier are turned off. Unplug all equipment before making any connections so that there will be no unwanted signal transients that can damage equipment or speakers.

Input connections

Connecting the SA-44 to your source equipment is straightforward. Using the high-quality RCA audio interconnect cables, match the output channel designations on the rear of your source equipment to the input jacks on the rear panel of your amplifier that have the same channel name.

When making connections with RCA type plugs on interconnect cables, make certain to gently, but firmly, insert the plug into the jack. Loose connections can cause intermittent sound and may damage your speakers. Some quality RCA plugs may be very tight, and it is important to secure a proper connection between the interconnection cable and the input jack.

We suggest starting with the input gains on the rear of the SA-44 set to mid position. After it is installed and being tested these gains are used to set the different source input levels so they are roughly the same. Some sources such as DVD players have a very high output and may cause the SA-44 to send clipped signals to the speakers even at low volume levels, so we suggest lowering the input gains of that input in this case to stop the clipping.

Speaker connections

The SA-44 has four stereo 30 watts per channel amplified outputs. Channel 1 also has line level outputs to connect to larger powered amplifiers.

To ensure that the high quality signals produced by your amplifier are carried to your speakers without loss of clarity or resolution, Sound Acoustics advises that you use high-quality speaker wire. Many brands of wire are available — the choice may be influenced by the distance between your speakers and the amplifier, the type of speakers you use, personal preferences, along with other factors.

Regardless of the brand or type of speaker wire chosen, we suggest that you use a wire constructed of fine, multi-strand copper with a gauge of 16 or less (the lower the number, the thicker the cable). Wire with a gauge of 16 may be used for short runs of less than 12 feet. We do not recommend that you use any wires with an AWG equivalent of 18 or higher due to the power loss and degradation in performance.

To connect the amplifiers to your speakers, a removable plug with screws is provided for each stereo channel output. Strip approximately 1/4 inch of insulation from the end of each wire and carefully twist the strands of each conductor together. Be sure not to cut the individual strands or twist them off. All strands must be used for optimal performance. Insert the wire into the plug and screw the screws very tight. Inspect that no wire "hairs" that can short circuit are not in the plug.

Correct polarity connections are important to maintain proper speaker phasing. When speaker

phasing is correct, all speakers move in and out at the same time preserving the imaging of the program material. Out-of-phase connections mean that some turn off, check your speakers to verify that they are operating properly. If all other potential sources of trouble check out properly, contact Sound Acoustics for further assistance.

Run the cables to speaker locations. Do not coil any excess cable, as this may become an inductor that creates frequency response variations in your system. Lastly, connect the wires to the speakers, again being aware of proper polarity. Remember to connect the negative, or black wire, to the matching terminal on the speaker. The positive, or red wire should be connected to the matching terminal on the speaker.

Note: While most speaker manufacturers follow industry convention of using red terminals for positive connections and black terminals for negative, some manufacturers may vary from this configuration. To ensure proper phase connections, and optimal performance, consult the identification plate on our speaker terminals, or the speaker's manual to verify polarity. Contact the speaker's manufacturer if you do not know the polarity of your speakers.

Keypad Connection

The SA-44 outputs are controlled by the SA-40 keypad and a Sound Acoustics SA-40R remote control.

Only one SA-40 keypad can be used in a zone.

Note: SA-40 keypads are not designed for outdoor use, high humidity, high temperatures or any extremes.

The SA-40 contains an almost all brand infrared repeater and most functions can be controlled by the Sound Acoustics SA-40R remote control. SA-40R commands can easily be stored in a learning remote.

The SA-40 is connected to the SA-44 with CAT5e or CAT6 wire. Each keypad needs to have a home run on one wire. Each room or zone has a unique IR pass-thru port as indicated on the rear of the SA-44. In addition there is an all room IR pass-thru port. All eight of the CAT5 wire conductors are used.

Note: It is very important to use a top quality RJ45 8/8 crimper tool. We strongly suggest using a cat 5 / RJ45 electronic tester to verify the wire conductors. We recommend the T568A wiring method, which is shown below. The functions of each wire connection are also shown.

future use brown
future use white/brown
Infrared orange
ground white/blue
+12 vdc blue
future use white/orange
SDA green
SCL white/green

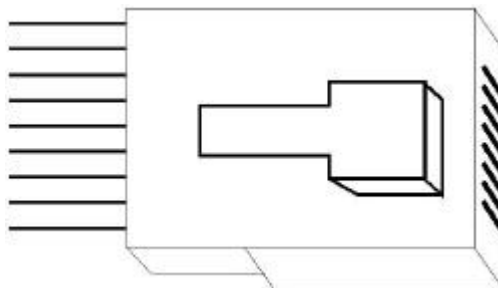

Run CAT5 wire from the keypad location to the SA-44 location for each keypad. It isn't a bad idea to run a second cat5 wire run to each location to leave the installation more "future proof" and reliable. Leave an extra 1 m or 3 feet on each side to make it easier to work on. Add a RJ45 connector of the right type for the CAT5 wire you have selected (not all CAT5 wires are the same) and crimp the connector to the wire on each side. Plug the RJ45's into the SA-40 and correct SA-44 ports.

Note: SA-40 keypads do not require any programming.

Infrared connections

On the rear of the SA-44 there are four infrared pass through ports. Each of the 1 through 4 corresponds to the keypad port next to them. For example IR port #3 is the infrared output for keypads connected to KEYPAD #3. The infrared ALL is the combination of all of the four keypad ports.

Using this method of infrared routing you can have six sources the same (like 6 identical AM/FM tuners) one for each zone and they can be controlled individually in each room. Each port can control up to 8 devices using 4 of our optional IR34a emitters and one IR55 connection block.

Each infrared port is a standard 3.5mm mono jack.

Infrared Selection

The SA-40 keypads have a very small switch on the rear labeled 38K and 56K. Almost all infrared remotes use 38k. A few use 56k. If you find your remote control does not work with our keypads we suggest you try moving the switch to 56k and see if it now works. When you do this some remotes that use 38k will now not work.

Link connections

On the rear of the SA-44 amplifier there is a 3.5mm stereo jacks labeled LINK. This port connect two SA-44's together so they can share certain commands (such as All Off)

When connecting two SA-44's together in one system you will need:

1. Up to fourteen (one for each active source) RCA Y patch cords
2. A 3.5mm stereo patch cord.

Normally the two SA-44's are near each other. If they are far apart then balancing baluns may be required to eliminate stray noise on the lines.

The procedure to connect the two controller amplifiers is:

1. Connect the Link jack on SA-44 #1 to the Link jack on SA-44 #2 using the 3.5mm stereo patch cord.
2. Connect all of the up to four sources using short as possible good quality RCA patch cords to SA-44 #1 and SA-44 #2 source inputs.

Trigger output

The mono 3.5mm connector on the rear of the SA-44 supplies 12 VDC (maximum 100 mA) when any or all of the zones are turned on.

SA-40 Keypad Functions

When the whole system is installed and the SA-44 is powered up each of the SA-40 keypads will undergo a diagnostic and eventually turn on to source 1 at a very low level. The only thing to program is the bass and treble for each room (explained below).

To turn off the zone either push the keypad button labeled off or the off button on the SA-40R remote control.

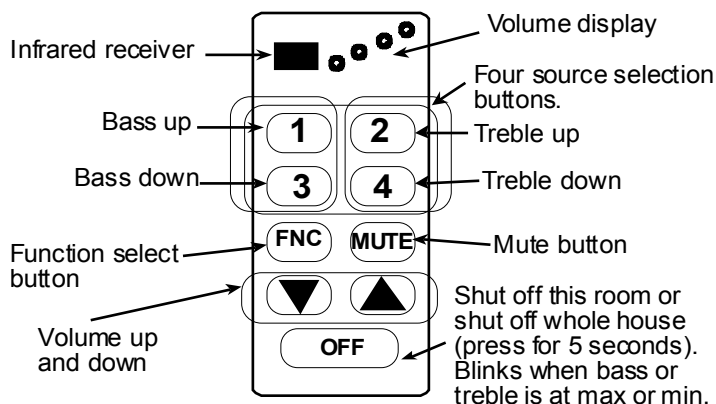

To turn on the zone on either press the source button or the off button on the remote or keypad. If you press the OFF button the zone will go back to the source selected when it was last shut off. In either case the zone goes to a preselected mid-low volume, not necessarily the volume selected when it was last shut off.

To adjust the volume press the volume switch up or down as desired. The relative volume is shown in the led displays on the top.

To temporarily mute the output, press the mute button on either the remote or keypad. It mutes the output in this room.

Equalization

Equalization cannot be performed from the remote control. To enter the equalization mode press the FNC button. The four source button will have their led's running in a circular motion. To raise the bass output in this room only push and hold the source 1 button until the desired effect is achieved.

When the maximum bass is selected the OFF button will blink. Do the same with bass down, treble up and treble down. The parameters selected go into memory and are retained even if the power to the system is turned off.

Press the FNC button again to exit the equalization mode.

To go back to a flat frequency response, enter the equalization mode again and when in this mode with the source leds going in a clockwise direction press the MUTE button. The equalization is now flat. Again to exit this mode press the FNC mode and

Sound Acoustics Service information

The SA-44 amplifier does not contain any user serviceable parts inside. If you suspect a problem that may require servicing, contact us at www.MySoundAcoustics.com. It is extremely important that only an authorized service dealer make any repairs. This will ensure proper service and preserve the protection of your warranty. Keep your receipt in a safe place so that it will be available to verify the purchase date, should you experience a problem covered by Sound Acoustics System's warranty.

Troubleshooting

Your Sound Acoustics amplifier is designed for trouble-free operation. If you follow the instructions in this manual, you should enjoy many years of high-quality listening enjoyment. However, as with any sophisticated device, there may be occasional problems upon initial installation, or during the life of the amp. The items on the list below are a brief guide to the minor problems that you may be able to correct yourself. If these solutions do not help, or if the problem persists, contact us for assistance at 1-604-707-0116 in Canada and the USA. We are in the Pacific time zone.

Problem	Solution(s)
Amplifier won't turn on	Master power switch turned off (No power light LED). Turn on Master Power Switch.
Amplifier turns on, but no audio from one or more channels	Input plugs not connected to proper jack or are loose. Check input connections.
No audio from one or more Channels	Speakers are not connected properly. Check speaker connections at amp and speaker.
Audio levels differ from sources	Improper settings or output levels from source device. Check the settings on your preamp, processor or controller. Also verify gain settings on the source inputs on the SA-44 rear panel.
Audio plays and then cuts off	Amplifier may be shorted. Check speaker connections for short-circuit at amp and speaker.

Care, maintenance, and cleaning

When the SA-44 amp becomes dirty, wipe it with a clean, dry, soft cloth. If necessary, first wipe the surface with a slightly dampened soft cloth with mild soapy water, then with a fresh cloth dampened with clean water. Wipe dry immediately with a dry cloth. NEVER use benzene, thinner, alcohol, or any other volatile cleaning agent. Do not use abrasive cleaners, as they will damage the finish of the metal parts. Avoid spraying insecticide, waxes, polishing agents, or any aerosol product near the SA-44.

Limited Warranty

Sound Acoustics warrants that each SA-44 and SA-40 ("the Product") sold hereunder will conform to and function in accordance with the written specifications of Sound Acoustics. Said limited warranty shall apply only to the first person or entity that purchases the Product for personal or business use and not for the purpose of distribution or resale. Said warranty shall continue for a period of three years from the date of such purchase. Sound Acoustics does not warrant that the Product will meet the specific requirements of the first person or entity that purchases the Product for personal or business use. Sound Acoustics's liability for the breach of the foregoing limited warranty is limited to the repair or replacement of the Product or refund of the purchase price of the Product, at Sound Acoustics's sole option. Replacement Product may be re-furbished in "like-new" condition, at Sound Acoustics' sole discretion. To exercise the Purchaser's rights under the foregoing warranty, the Product must be returned at the Purchaser's sole cost and expense, to Sound Acoustics or to any authorized Sound Acoustics service center provided, and the Product must be accompanied by a written letter explaining the problem and which includes (i) proof of date of purchase; (ii) the dealer's name; and (iii) the model and serial number of the Product. When sending your unit in for repair, please ship your unit in its original packing material or a Sound Acoustics approved ATA Shipping Case, or have a professional packaging company pack the unit. Please insure your shipment for its full value. A return authorization number, issued by the Sound Acoustics customer service department, must also be clearly displayed on the outside of the shipping carton containing the Product.

Note: Re-manufactured Products are exempt from the foregoing Limited Warranty. Please refer to the Re-manufactured Product Warranty for applicable warranty information.

WARRANTY LIMITATION AND EXCLUSION

Sound Acoustics shall have no further obligation under the foregoing limited warranty if the Product has been damaged due to abuse, misuse, neglect, accident, unusual physical or electrical stress, unauthorized modifications, tampering, alterations, or service other than by Sound Acoustics or its authorized agents, causes other than from ordinary use or failure to properly use the Product in the application for which said Product is intended.

DISCLAIMER OF UNSTATED WARRANTIES

THE WARRANTY PRINTED ABOVE IS THE ONLY WARRANTY APPLICABLE TO THIS PURCHASE. ALL OTHER WARRANTIES, EXPRESS OR IMPLIED, INCLUDING, BUT NOT LIMITED TO, THE IMPLIED WARRANTIES OF MERCHANTABILITY AND FITNESS FOR A PARTICULAR PURPOSE ARE DISCLAIMED. THERE ARE NO WARRANTIES THAT EXTEND BEYOND THE FACE HEREOF AND THE FOREGOING WARRANTY SHALL NOT BE EXTENDED, ALTERED OR VARIED EXCEPT BY WRITTEN INSTRUMENT SIGNED BY Sound Acoustics. SOME STATES DO NOT ALLOW LIMITATIONS ON HOW LONG AN IMPLIED WARRANTY MAY LAST, SO SUCH LIMITATIONS MAY NOT APPLY TO YOU.

LIMITATION OF LIABILITY IT IS UNDERSTOOD AND AGREED THAT SOUND ACOUSTICS' LIABILITY WHETHER IN CONTRACT, IN TORT, UNDER ANY WARRANTY, IN NEGLIGENCE OR OTHERWISE SHALL NOT EXCEED THE RETURN OF THE AMOUNT OF THE PURCHASE PRICE PAID BY PURCHASER AND UNDER NO CIRCUMSTANCES SHALL SOUND ACOUSTICS BE LIABLE FOR SPECIAL, INDIRECT, INCIDENTAL OR CONSEQUENTIAL DAMAGES OR LOST PROFITS, LOST REVENUES OR LOST SAVINGS. THE PRICE STATED FOR THE PRODUCT IS A CONSIDERATION IN LIMITING SOUND ACOUSTICS' LIABILITY. NO ACTION, REGARDLESS OF FORM, ARISING OUT OF THE AGREEMENT TO PURCHASE THE PRODUCT MAY BE BROUGHT BY PURCHASER MORE THAN ONE YEAR AFTER THE CAUSE OF ACTION HAS ACCRUED. SOME STATES DO NOT ALLOW THE EXCLUSION OR LIMITATION OF INCIDENTAL OR CONSEQUENTIAL DAMAGES SO THE ABOVE LIMITATION OR EXCLUSION MAY NOT APPLY TO YOU. THIS LIMITED WARRANTY GIVES YOU SPECIFIC LEGAL RIGHTS, AND YOU MAY ALSO HAVE OTHER RIGHT WHICH VARIES FROM STATE-TO-STATE OR PROVINCE-TO-PROVINCE.

Copyright 2009 Sound Acoustics. All Rights Reserved.

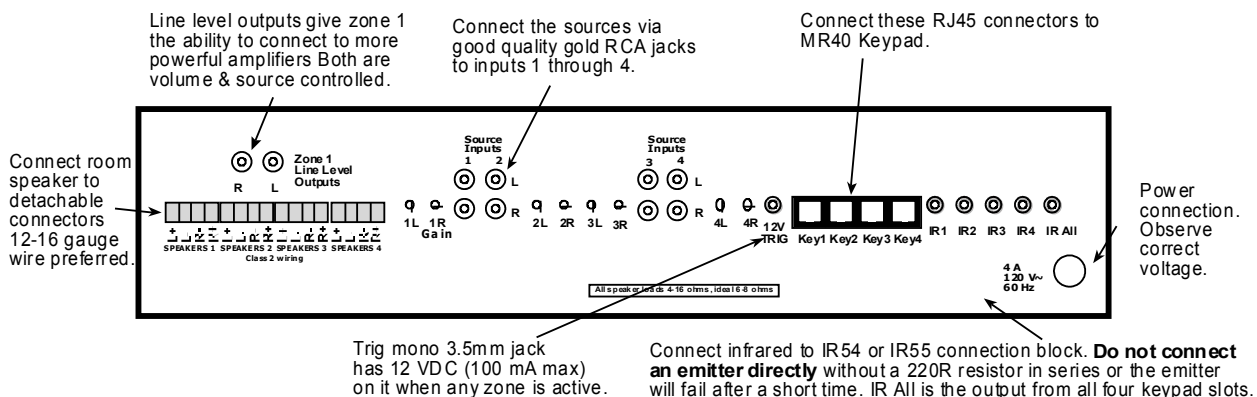

Sound Acoustics Contact Information

1360 Frances Street
Vancouver, BC
V5L 1Y9

Tel: 604.707.0116

E-mail: info@mysoundacoustics.com

Web site: www.mysoundacoustics.com